

25-C Concealed Vertical Device

Concealed Vertical Rod Panic Exit Device, Metal Door, LHR Shown, RHR Opposite

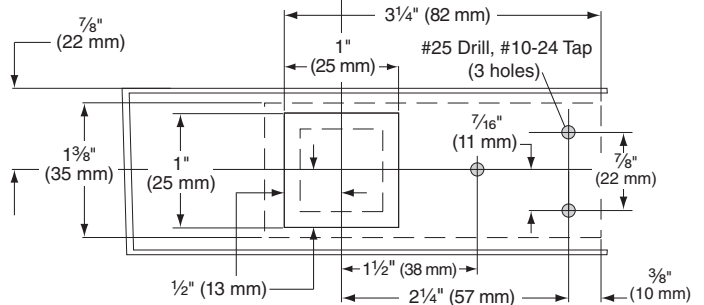
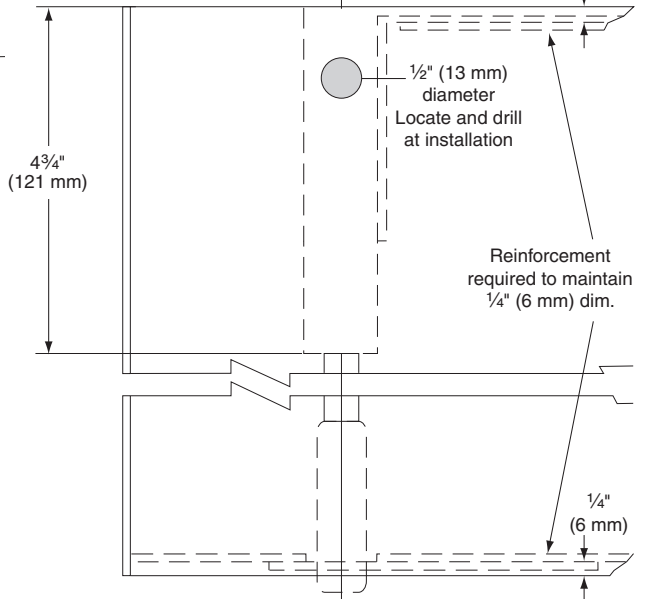
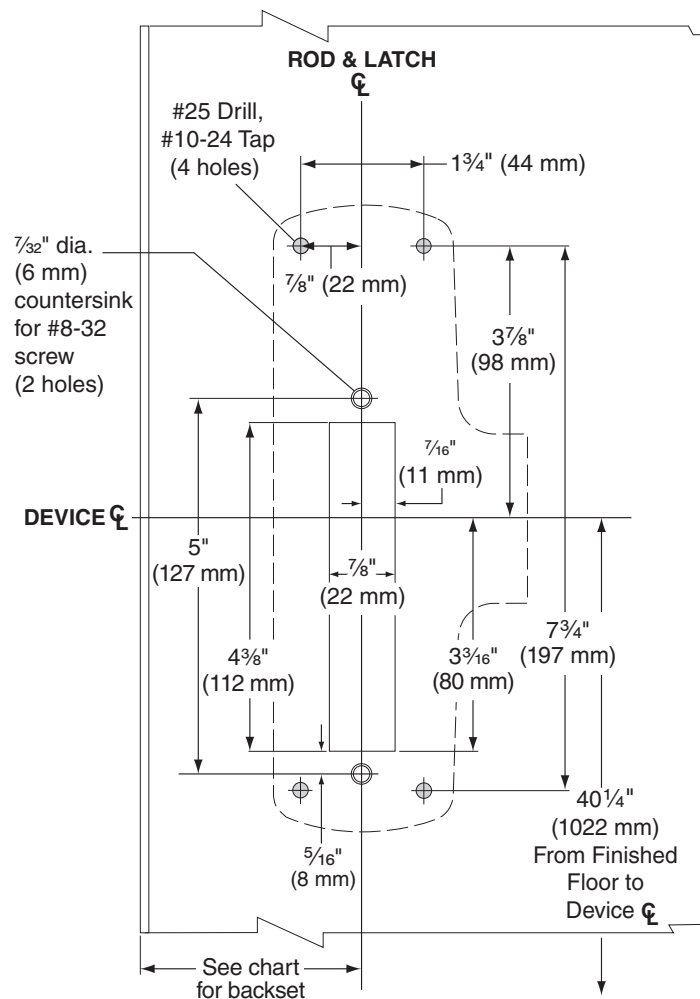
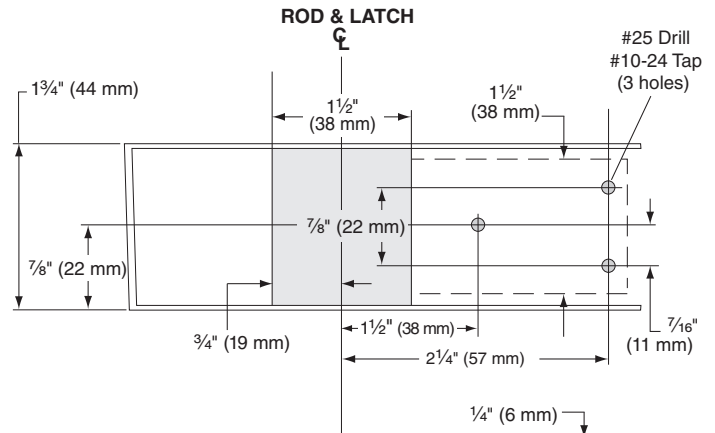
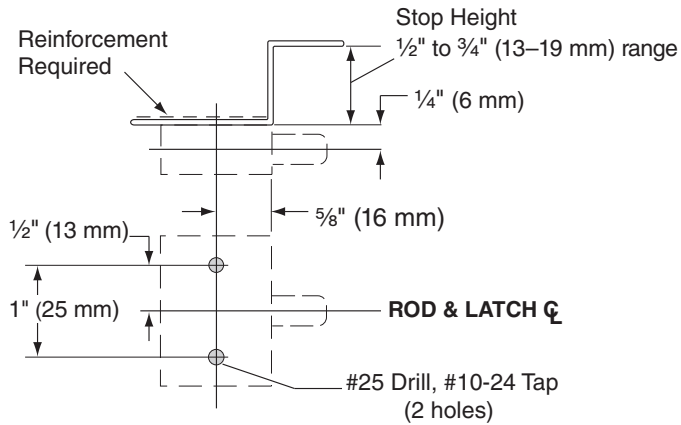

- For Less Bottom Rod (LBR) application, omit bottom preparation.
- For outside trim, see trim template for door preparation.
- For sexbolt preparation, refer to Template T-4014.
- See Master Sheet #0100 for suggested reinforcing.

Stile Width	Backset
3 $\frac{1}{2}$ " Min. to 4 $\frac{1}{2}$ "	1 $\frac{3}{4}$ "
4 $\frac{1}{2}$ " to Flush	2 $\frac{3}{4}$ "

TEMPLATE
T-1231-a