

(F)25-R Rim Device

Rim Panic and Fire Exit Device, Metal Door, LHR Shown, RHR Opposite

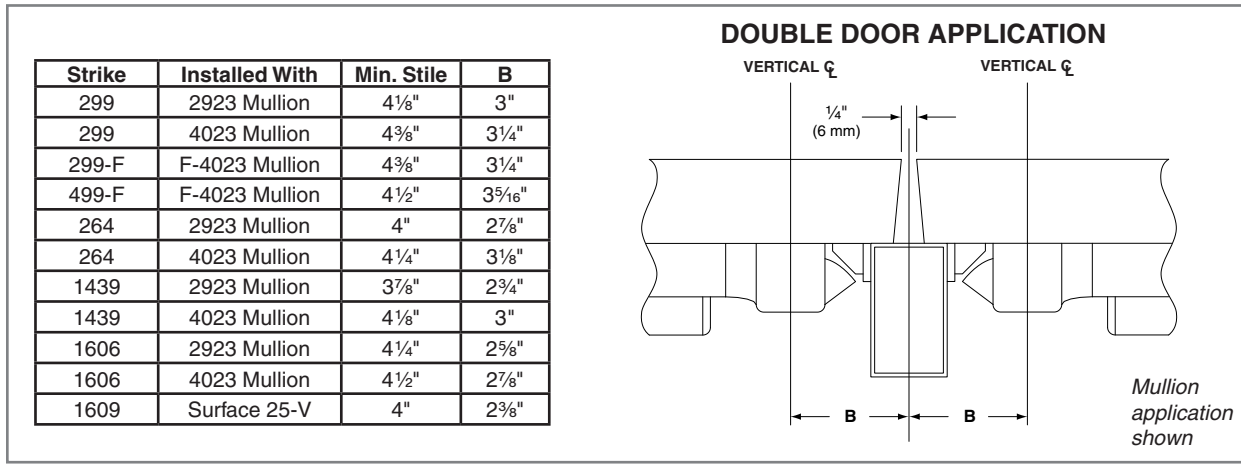
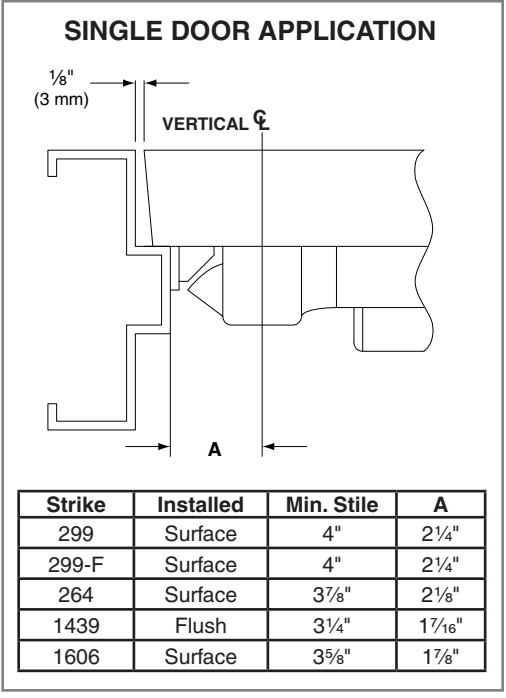
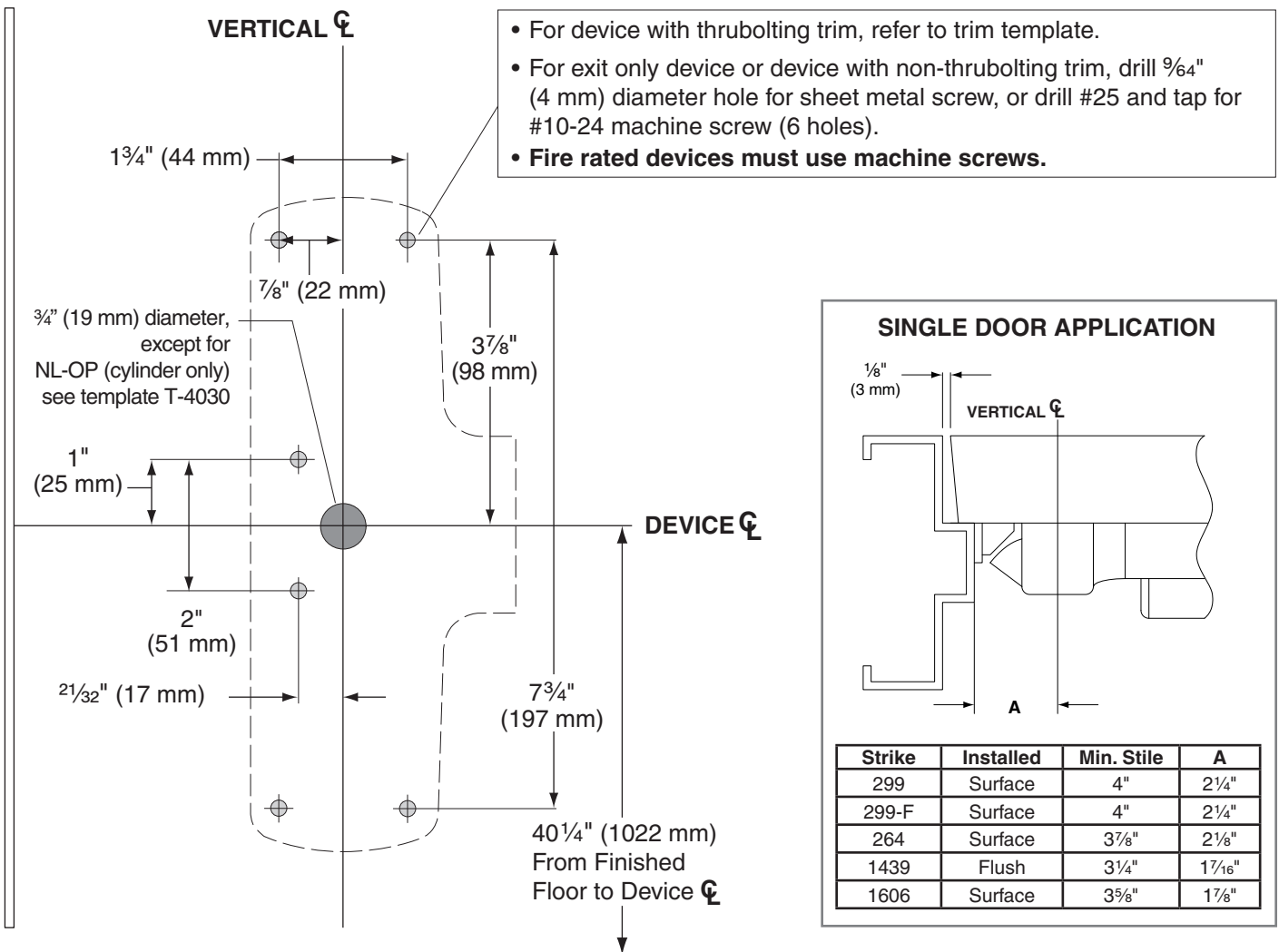

- For sexbolt preparation, refer to Template T-4014.
- For outside trim, see trim template for door preparation.
- See Master Sheet #0100 for suggested reinforcing.

TEMPLATE
T-1201-a