

# F-25-C Concealed Vertical Device

Concealed Vertical Rod Fire Exit Device, Metal Door, LHR Shown, RHR Opposite

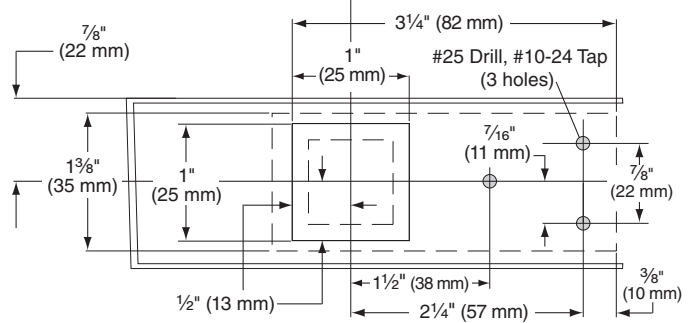
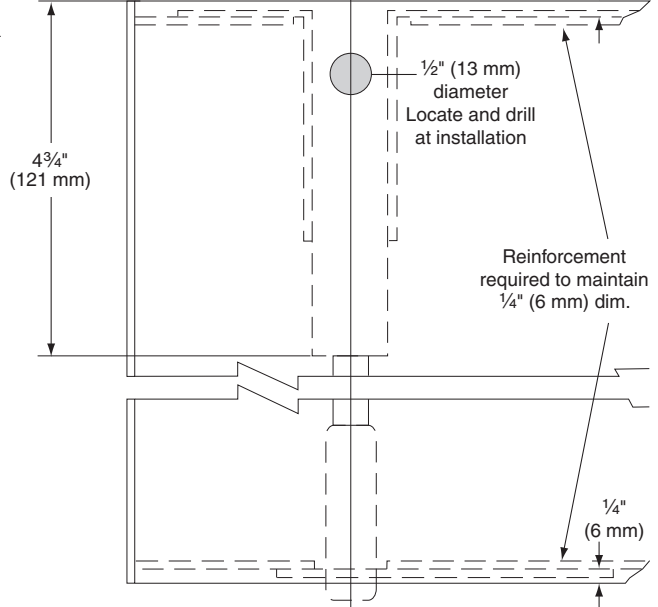
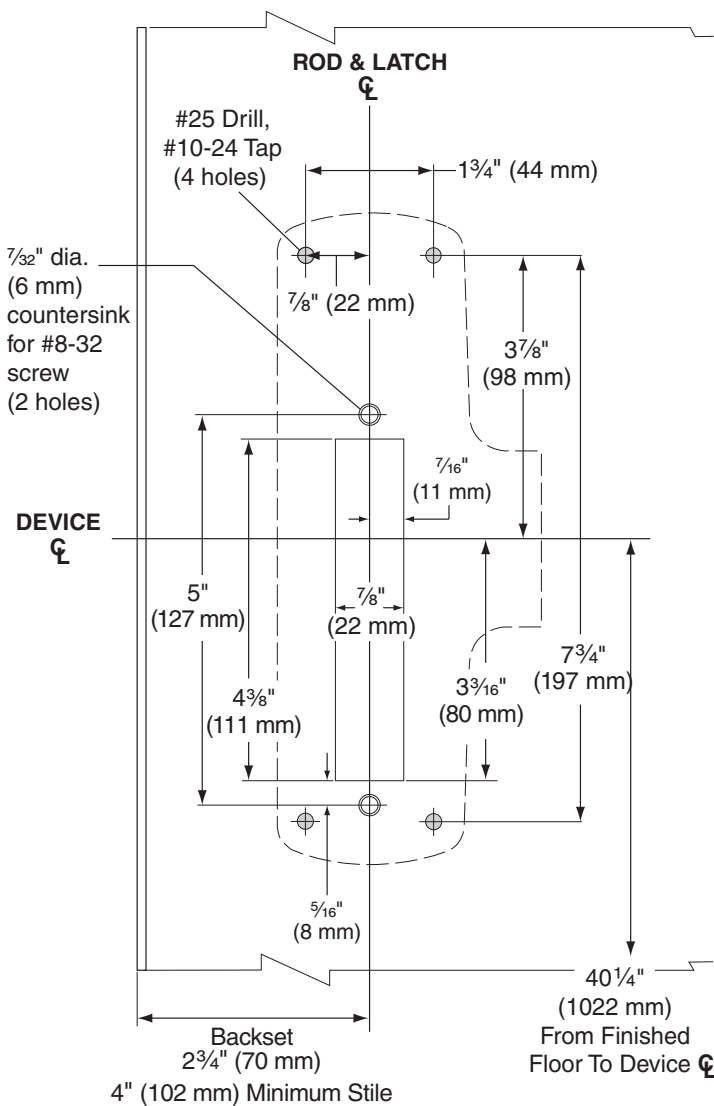
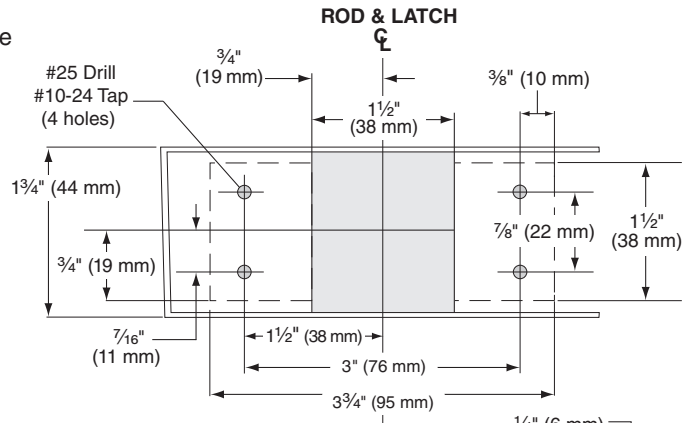
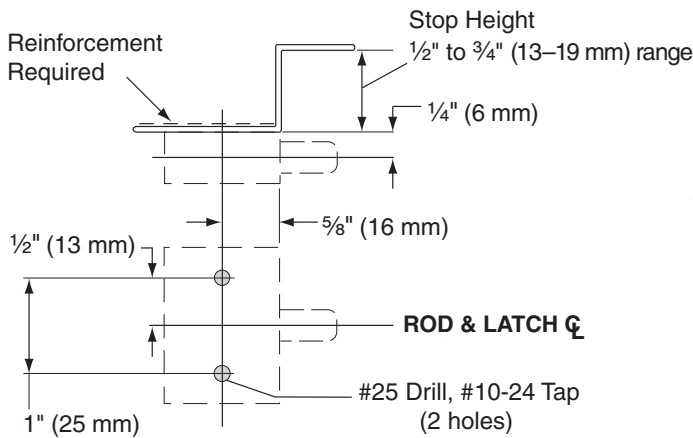

- See Master Sheet #0100 for suggested reinforcing.
- For fire rated Less Bottom Rod (LBR) application omit bottom preparation.
- For fire rated Less Bottom Rod (LBR) application, refer to template T-5494 for auxiliary fire latch.

- For outside trim, see trim template for door preparation.
- For sexbolt preparation, refer to Template T-4014.

**TEMPLATE**  
**T-1230-a**