

# F-25-C Concealed Vertical Device

Concealed Vertical Rod Panic and Fire Exit Device With Metal Edge 5" Stile, Wood Door, LHR Shown, RHR Opposite

## RELEASE PLUNGER DETAIL

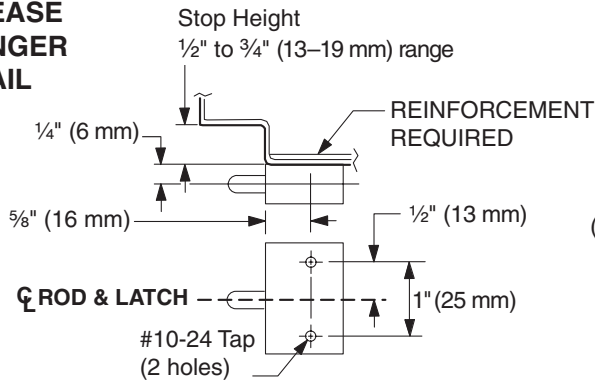

## ROD & LATCH CL

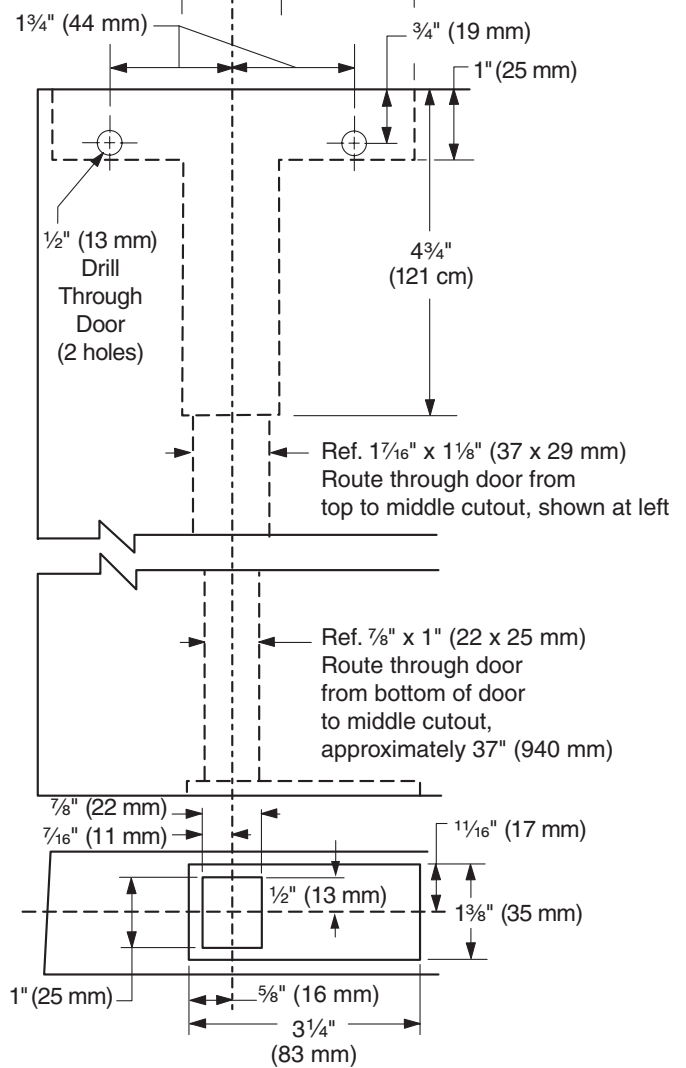
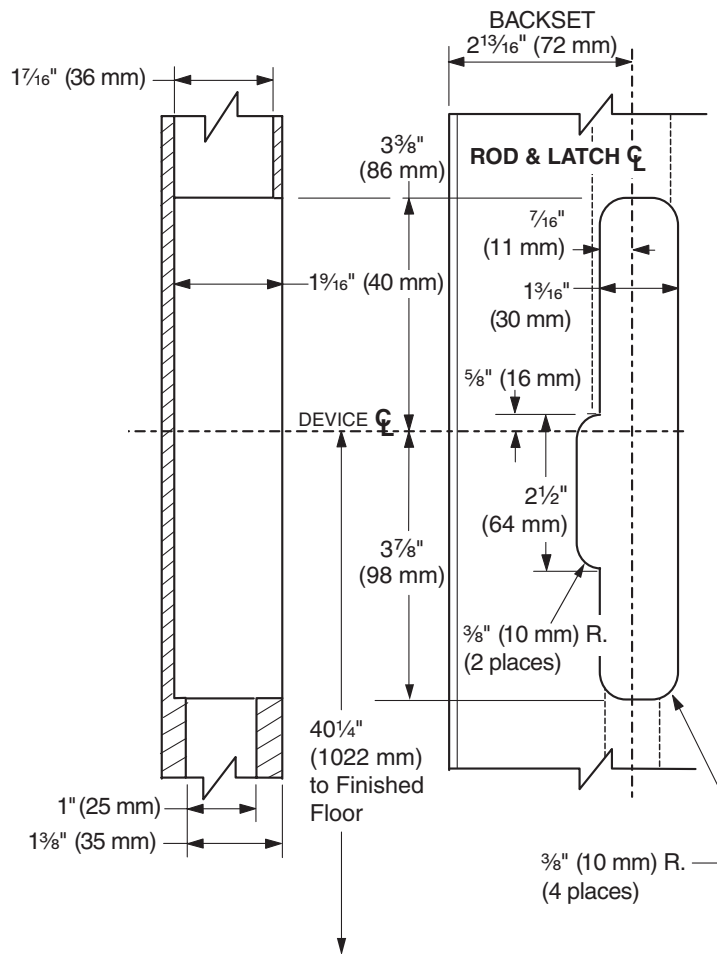
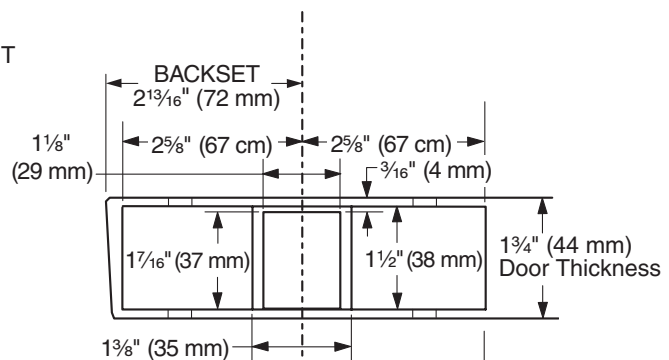

- For outside trim, see trim template for door preparation.
- See Template W-1250 for steel door wrap preparation.
- For Less Bottom Rod (LBR) application (20 minute rating only), refer to Template W-5494 for auxiliary fire latch preparation.

TEMPLATE

**W-1242-a**

# (F)25-C Top Latch Preparation

Fire Rated Devices - No Metal Channel - Top Latch Reinforcing Plates Construction - 20 Minute, Wood Door, LHR Shown, RHR Opposite

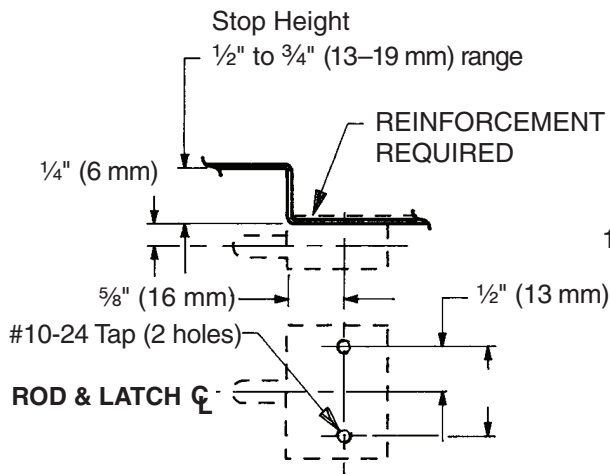

**RELEASE PLUNGER DETAIL**

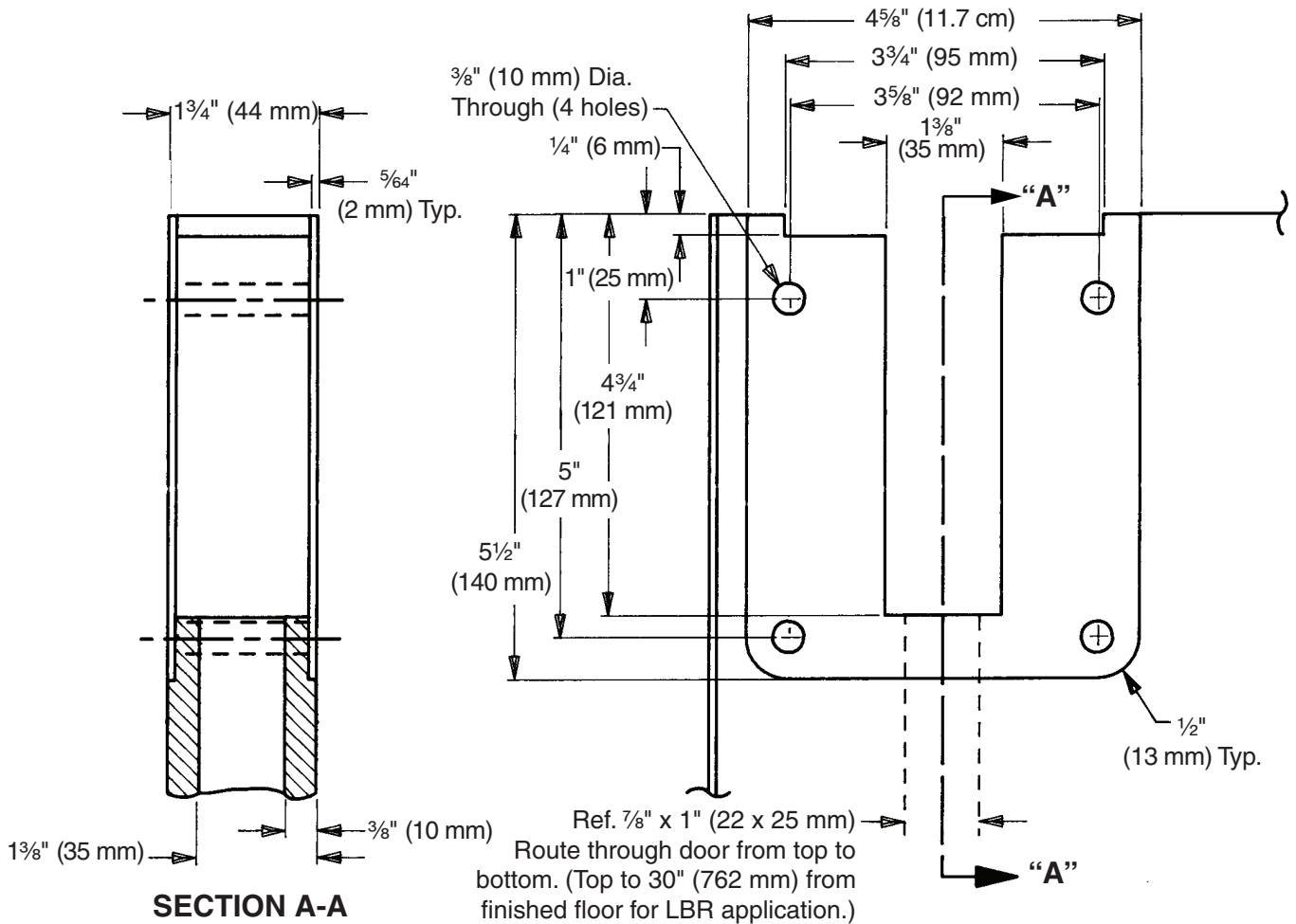
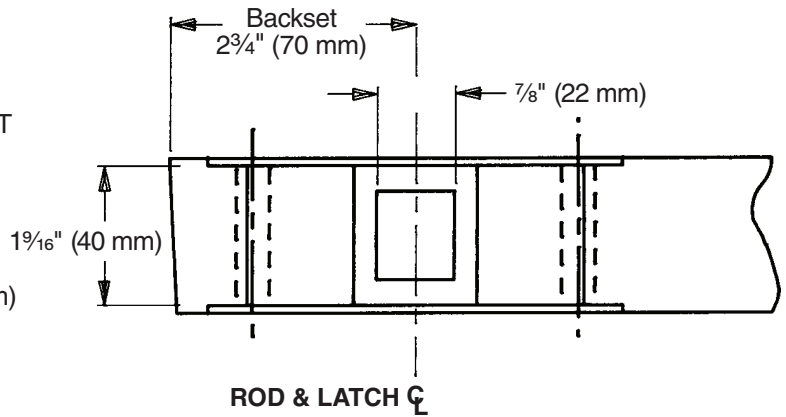

- For Less Bottom Rod (LBR) application omit bottom bolt preparation. On fire rated applications, refer to Template W-5494 for auxiliary fire latch preparation.
- For bottom bolt preparation, refer to Template W-1283.
- For outside trim, see trim template for door preparation.
- For (F)25-C centerslide preparation, refer to Template W-1281.

**TEMPLATE**  
**W-1282-a**



