



Price Page

Glynn Johnson

Vendor Site

90 Series Surface Heavy Duty Overhead Door Holders/Stops

90 series door holders and stops provide long lasting protection for doors, frames and hardware. All models incorporate a heavy-duty channel/slide-arm design and offset jamb bracket. This design allows for simple field modification.

Stocked Product

Stock 90 S Series (Stop-Only)

When the Hold-Open function is not a requirement. The Stop only model provides a reliable method of door control. The Stop only models may be used on fire doors



Finish 32D; Contact sales department for other finishes

Sizes: 4,5

Optional Functions: Hold Open (H), Friction (F)

Special Order: Sizes 2,3,6

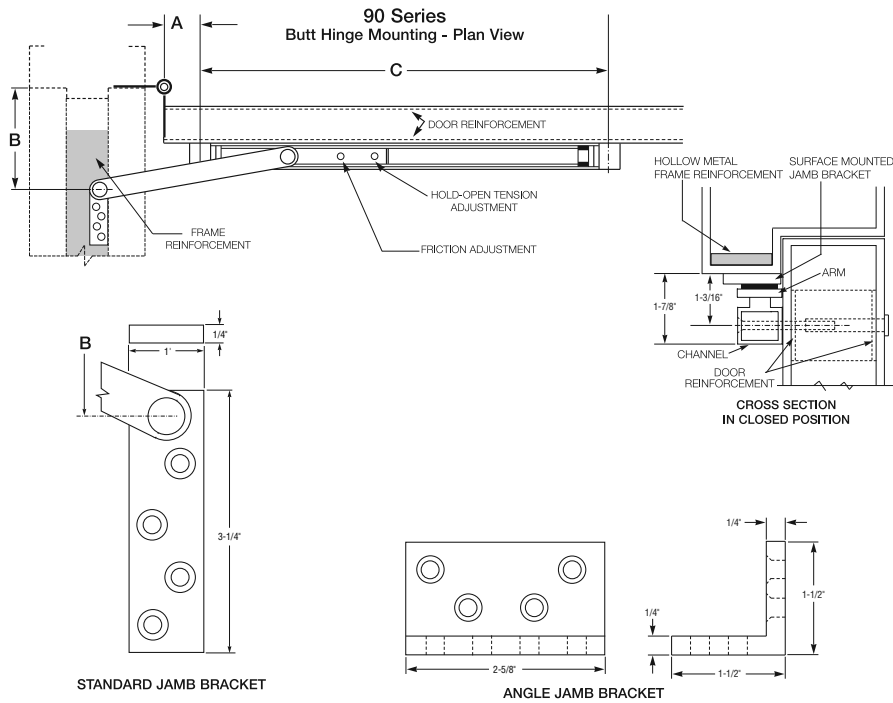

SIZE	BUTTS/OFFSET PIVOTS				CENTER HUNG			
	DOOR OPENING	STOP ONLY	HOLD OPEN	FRICTION	DOOR OPENING	STOP ONLY	HOLD OPEN	FRICTION
1	----	----	----	----	----	----	----	----
2	23-1/16"-27"	902S	902H	902F	27-1/16"-33"	902S	902H	902F
3	27-1/16"-33"	903S	903H	903F	33-1/16"-39"	903S	903H	903F
4	33-1/16"-39"	904S	904H	904F	39-1/16"-45"	904S	904H	904F
5	39-1/16"-45"	905S	905H	905F	45-1/16"-51"	905S	905H	905F
6	45-1/16"-51"	906S	906H	906F	51-1/16"-59"	906S	906H	906F

G-J Model	BHMA*	FED. Spec.
902 - 906H	C02511	1161
902 - 906S	C02541	1161A
902 - 906F	C02531	—

* First numeral (0) designates optional material.

To specify:

Brass material, change 0 to 1 (i.e. C12511)

Stainless Steel material, change 0 to 5 (i.e. C52511)

Steel material, change 0 to 8 (i.e. C82511)

Note: This chart illustrates the most common types of hinging and door opening sizes. For unusual door details, contact Glynn-Johnson for availability.



Price Page

Glynn Johnson

Vendor Site

100 series Heavy Duty Concealed Overhead Door Holders/Stops

100 series provide a wide range of optional features and are ideal for use on entrance and vestibule doors, large doors, or door subject to abuse. These models are also furnished with an offset style jamb bracket designed for heavy duty applications, 100 series models will provide long lasting protection to doors, frames, hinges and other hardware. Templates provided allow for variable mounting positions, ranging from 85 degrees to 110 degrees of opening.

100 series is non handed

Stocked Product

100 S Series Stop only

When the Hold-Open function is not required, the Stop-Only function provides the same effective door control. Can be used on fire doors. The friction tension is adjusted using an allen wrench and an open end wrench.

Finish 32D Contact sales department for other finishes

Sized: 2, 3, 4

Optional Functions: Hold Open (H), Friction (F)

Special Order: Sizes 1,5,6

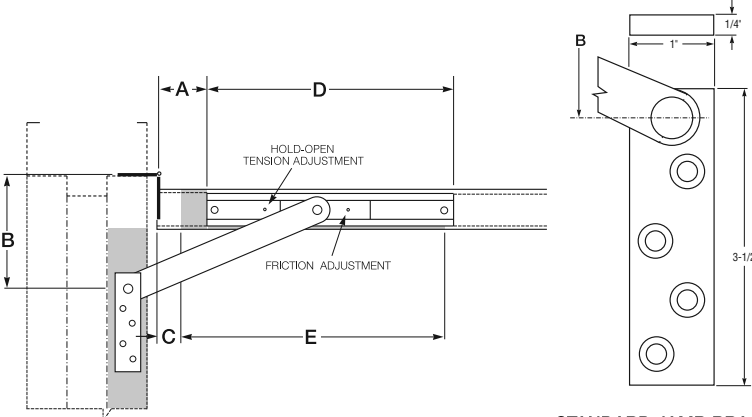
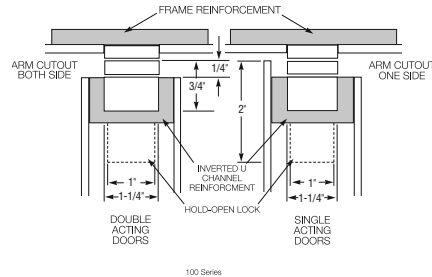
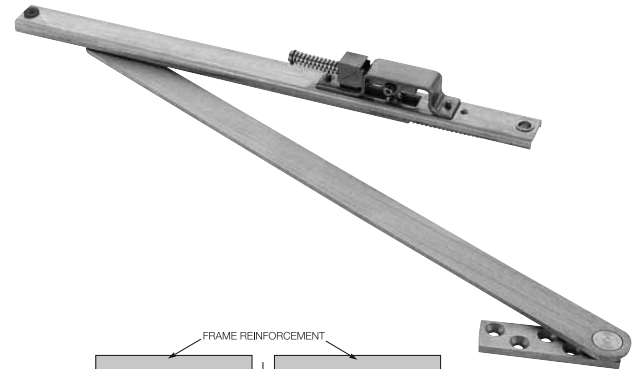

STANDARD JAMB BRACKET

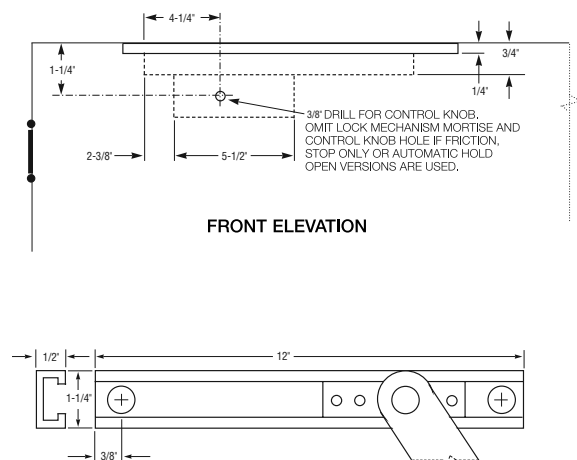

OPTIONAL JAMB BRACKET "ADJ"

100 Series Sizing Chart									
BUTTS/OFFSET PIVOTS					CENTER HUNG				
SIZE	DOOR OPENING	STOP ONLY	HOLD OPEN	FRICTION	DOOR OPENING	STOP ONLY	HOLD OPEN	FRICTION	
1	18"-23"	101S*	101H*	101F*	----	----	----	----	
2	23-1/16"-27"	102S*	102H*	102F*	----	----	----	----	
3	27-1/16"-33"	103S	103H	103F	33-1/16"-39"	103S	103H	103F	
4	33-1/16"-39"	104S	104H	104F	39-1/16"-45"	104S	104H	104F	
5	39-1/16"-45"	105S	105H	105F	45-1/16"-51"	105S	105H	105F	
6	45-1/16"-54"	106S	106H	106F	51-1/16"-59"	106S	106H	106F	

Note: This chart illustrates the most common types of hinging and door opening sizes. For unusual door details, contact Glynn-Johnson for availability.

*These sizes are not available for use with offset pivots. Also not available with the ADJ option.

BHMA/ANSI, A156.8 & FED. Spec. Cross Reference		
G-J Model	BHMA*	FED. Spec.
101-106 H	C01511	1160
101-106 S	C01541	----
101-106 F	C01531	----

* First numeral (0) designates optional material.

To specify:

Brass material, change 0 to 1 (i.e. C11511)

Stainless Steel material, change 0 to 5 (i.e. C51511)

BHMA

All 100 series models are designed for heavy-duty applications and far exceed BHMA cycle test and force test requirements for Grade 1 holders and stops.



Price Page

Glynn Johnson

Vendor Site

412 Series Medium Concealed Overhead Door Holders/Stops

410 series holders and stops are designed for medium to light duty applications, They are ideal for openings that are subject to normal activity, providing protection for the door, frame and hinges

All models incorporate the popular channel/slide-arm design and offset jamb brackets.

Non handed

Stocked Product

410 S Series Stop only

When Hold-Open function is not a requirement. May be used on fire doors

Finish 32D; Contact sales department for other finishes
 Sizes: 2,3,4

Optional Functions: Hold Open (H), Friction (F)
 Special Order: Sizes 1,5,6

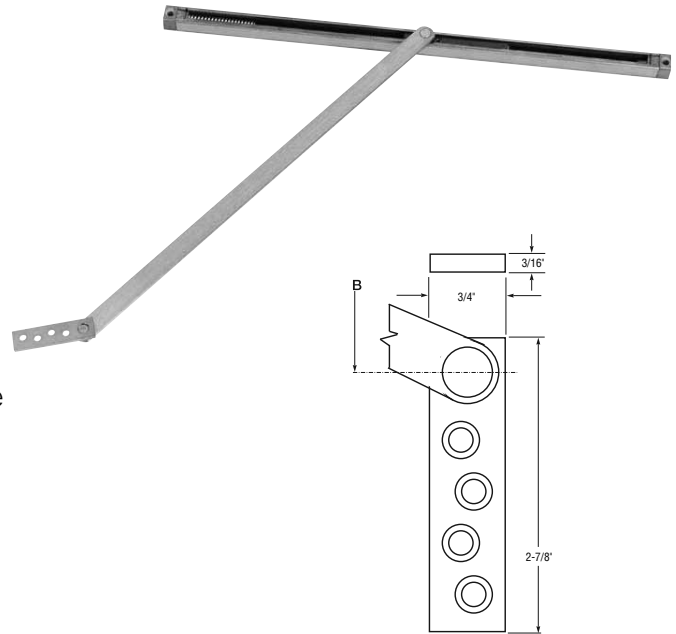

STANDARD JAMB BRACKET

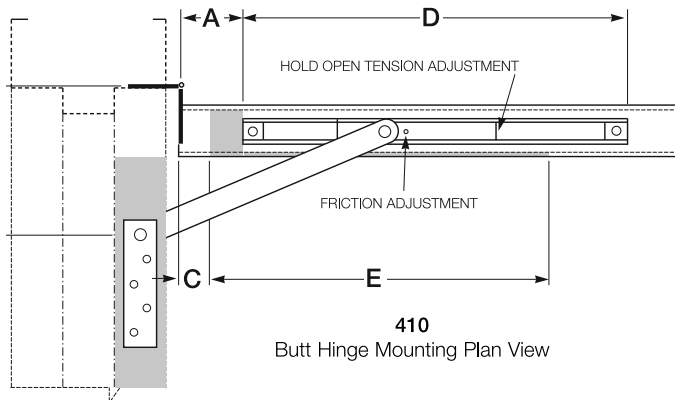

410
Butt Hinge Mounting Plan View

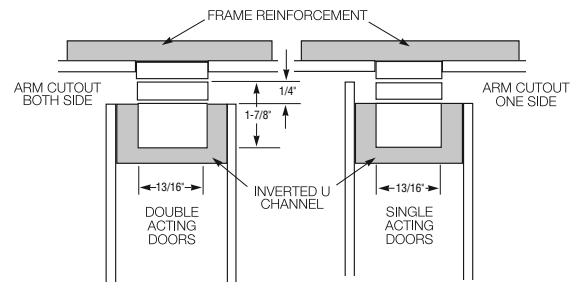

CROSS SECTION IN CLOSED POSITION

410 Series Sizing Chart

SIZE	BUTTS/OFFSET PIVOTS				CENTER HUNG			
	DOOR OPENING	STOP ONLY	HOLD OPEN	FRICTION	DOOR OPENING	STOP ONLY	HOLD OPEN	FRICTION
1	18"-23"	411S	411H	411F	----	----	----	----
2	23-1/16"-27"	412S	412H	412F	----	----	----	----
3	27-1/16"-33"	413S	413H	413F	33-1/16"-39"	413S	413H	413F
4	33-1/16"-39"	414S	414H	414F	39-1/16"-45"	414S	414H	414F
5	39-1/16"-45"	415S	415H	415F	45-1/16"-51"	415S	415H	415F

Note: This chart illustrates the most common types of hinging and door opening sizes. For unusual door details, contact Glynn-Johnson for availability.

The template information on this page is for reference only and is not intended to serve as an installation template. For complete dimensional information, refer to Glynn-Johnson template book.

BHMA/ANSI, A156.8 & FED. Spec. Cross Reference		
G-J Model	BHMA*	FED. Spec.
411-415 H	C04511	1166
411-415 S	C04541	1166A
411-415 F	C04531	1164

* First numeral (0) designates optional material.

To specify:

Brass material, change 0 to 1 (i.e. C14511)

Stainless Steel Material, change 0 to 5 (i.e. C54511)

Steel material, change 0 to 8 (i.e. C84511)



Price Page

Glynn Johnson

Vendor Site

450 series Medium Duty Surface Overhead Door Holders/Stops

450 series holders and stops are designed for medium to light duty applications, They are ideal for openings that are subject to normal activity, providing protection for the door, frame and hinges

All models incorporate the popular channel/slide-arm design and offset jamb brackets. The improved design makes it easier to change functions in the field.

Non handed

Stocked Product

Stocked 450 S (Stop-Only) and F (Friction Hold Open)

450 F Friction Hold-Open models provide an alternative holding method ideal for patient room doors, closet doors or similar applications where multiple Hold-Open positions are desired.

450S Stop only is used when Hold- Open function is not required. The Stop-Only function provides the same effective door control without keeping the door held open. May be used on fire doors.

Finish 32D; Contact sales department for other finishes

Sizes: 2,3,4

Optional Functions: Hold Open (H),

Special Order: Sizes 1,5,6

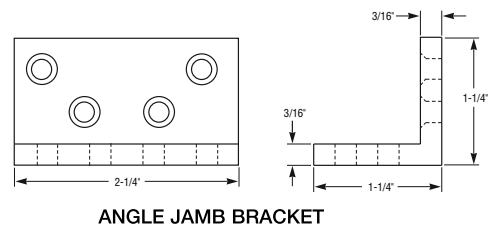
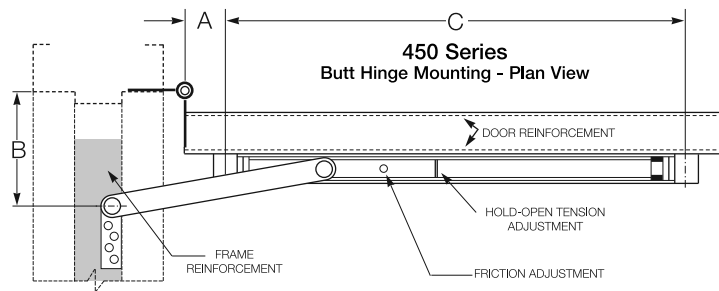
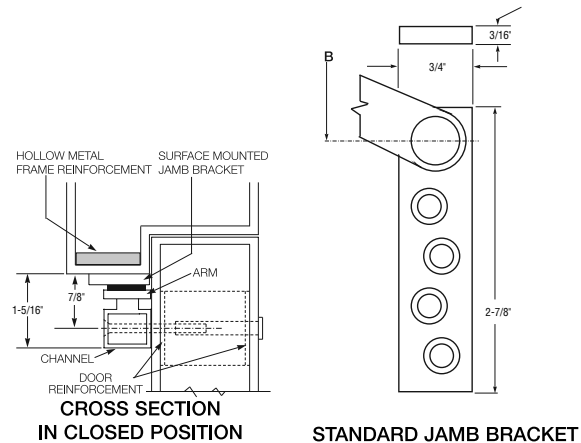

SIZE	BUTTS/OFFSET PIVOTS				CENTER HUNG			
	DOOR OPENING	STOP ONLY	HOLD OPEN	FRICTION	DOOR OPENING	STOP ONLY	HOLD OPEN	FRICTION
1	18"-23"	451S	451H	451F	23-1/16"-27"	451S	451H	451F
2	23-1/16"-27"	452S	452H	452F	27-1/16"-33"	452S	452H	452F
3	27-1/16"-33"	453S	453H	453F	33-1/16"-39"	453S	453H	453F
4	33-1/16"-39"	454S	454H	454F	39-1/16"-45"	454S	454H	454F
5	39-1/16"-45"	455S	455H	455F	45-1/16"-51"	455S	455H	455F

G-J Model	BHMA*	FED. Spec.
451-455 H	C05511	1166
451-455 S	C05541	1166A
451-455 F	C05531	1164

* First numeral (0) designates optional material.
 To specify:
 Brass/bronze material, change 0 to 1 (e.e. C15511)
 Stainless Steel Material, change 0 to 5 (i.e. C55511)
 Steel material, change 0 to 8 (i.e. C85511)

Note: This chart illustrates the most common types of hinging and door opening sizes. For unusual door details, contact Glynn-Johnson for availability.

The template information on this page is for reference only and is not intended to serve as an installation template. For complete dimensional information, refer to Glynn-Johnson template book.